



VIBRO/DYNAMICS® RFQ - Measuring Equipment Data Sheet

Request for: Quotation Budgetary Estimate

H&O DIE SUPPLY, INC
7200 Interstate 20
KENNE DALE TX 76060
Telephone: 1-800-222-5441 214-630-6660
Fax: 214-630-6693
www.hodie.com Email: sales@hodie.com

New Customer Quote No. _____

Customer Number: _____ Date: _____

(For Office Use Only)

Salesman: _____

Territory: _____

Name: _____ Phone: _____
Title: _____ Fax: _____
Company: _____ Email: _____
Address: _____ City: _____
State/Province: _____ Postal Code: _____ Country: _____

Send quote via:

- Fax
 Email
 Mail

I. MEASURING EQUIPMENT DATA English Metric

Machine Manufacturer: _____
Machine Model Number: _____ Serial Number: _____
Machine Type (CMM, optical comparator, surface plate, etc.): _____
Control Type: CNC Manual Other (explain) _____
Machine Weight: _____
Maximum Part Weight: _____
Weight of Fixtures (if any): _____
Number of Mounting Points: _____
(See Section V on the next page for more on mounting points.)

II. PROBE TRAVERSE ACTIONS (if applicable)

Moving Weight: _____ Which Axis? _____
Max. Acceleration (fill in those that apply): x-axis _____ y-axis _____ z-axis _____
Max. Velocity: _____

III. BRIDGE/GANTRY TRAVERSE (if applicable)

Moving Weight: _____ Which Axis? _____
Max. Acceleration (fill in those that apply): x-axis _____ y-axis _____ z-axis _____
Max. Velocity: _____

IV. PLEASE PROVIDE A GENERAL ASSEMBLY DRAWING, IF POSSIBLE



Machine Manufacturer: _____ Model Number: _____



V. CHECK TYPE OF MOUNTING POINT AND LIST APPLICABLE DIMENSIONS

For the following data, please indicate units of measure: English Metric

If blind tapped hole: Mounting Hole Diameter _____ Pitch _____ Depth _____

Type A

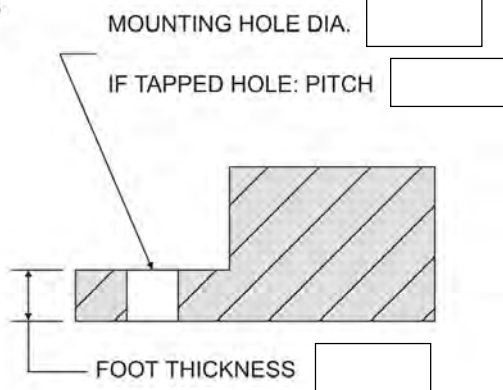

Type B

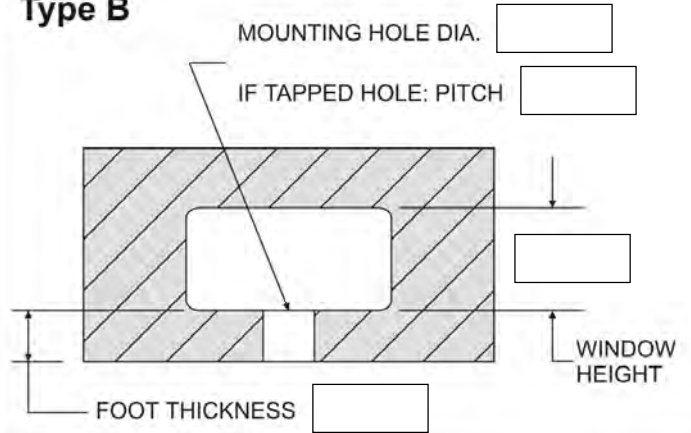

Type C

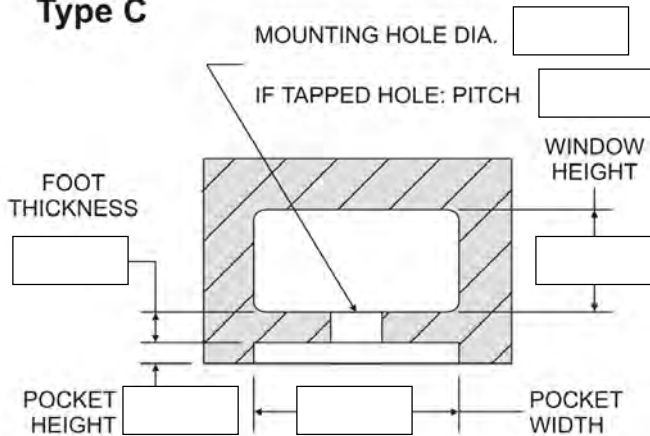

Type D

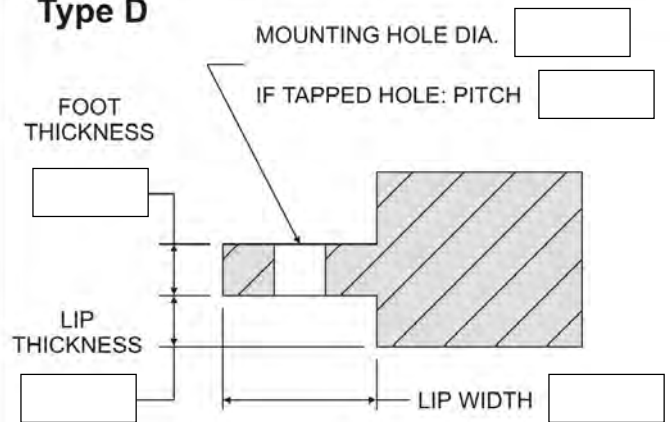

VII. Use the space below for sketches and/or comments on any special considerations.